



CELL INSTRUMENTS

One-Stop Material Testing Solutions

PRODUCT CATALOG

ONE STOP MATERIAL TESTING SOLUTIONS

CELL INSTRUMENTS CO., LTD.

► *DECADES OF EXPERIENCE*

► *PRESENCE IN 75+ MARKETS*

www.celtec.cn

info@celtec.cn

About Cell Instruments

Cell Instruments Co., Ltd., based in China, specializes in the development and manufacturing of testing equipment and solutions for a variety of industries, including packaging, plastics, rubber, adhesives, printing, food, pharmaceutical, cosmetics, and more. Cell Instruments' products are designed to help manufacturers ensure the quality, performance, and safety of their materials and products.

- **Innovation and Quality:** Cell Instruments focuses on providing high-quality testing instruments with advanced technology to meet international standards.
- **Global Reach:** Cell Instruments serves customers worldwide, offering both standard and customized testing solutions to meet specific industry requirements.
- **Customer Support:** Cell Instruments provides comprehensive after-sales service, including installation, training, and maintenance support to ensure optimal performance of their testing instruments.

Sectors Served

1. Plastic Film and Package Testing	2
2. Paper and Board Testing	3
3. Container Testing	3
4. Medical and Pharmaceutical Testing	4
5. Color Testing	4
6. Adhesiveness Testing	4
7. Plastics Testing	4
8. Textile Testing	4
9. Texture Analysis	4
10. Electronic Products Testing	5

Contents

1. Plastic Film and Package Testing	6
Leak Tester	6
Vacuum Leak Tester	6
Gross Leak Tester	6
Micro Leak Tester	6
Burst Tester	7
Digital Burst Tester	7
Manual Burst Tester	7
Heat Seal Tester	7
Standard Heat Seal Tester	7
Gradient Heat Seal Tester	7
Hot Tack Tester	7
Horizontal Hot Tack Tester	7
Vertical Hot Tack Tester	7
Tensile Tester	8
Flexible Material Tensile Tester	8
Universal Testing Machine	8
Coefficient of Friction Tester	8
Horizontal Plane COF Tester	8
Inclined Plane COF Tester	8
Impact Tester	8
Falling Dart Impact Tester	8
Pendulum Impact Tester	8
Falling Ball Impact Tester	8
Thickness Tester	9
Tear Tester	9
Digital Elmendorf Tear Tester	9
Manual Elmendorf Tear Tester	9
Flex Durability Tester	9
Four Station Flex Tester	9
Three Station Flex Tester	9
Shrink Tester	10
Free Shrink Rate Tester (Fluid Bath)	10
Shrink Rate and Force Tester (Hot Air Oven)	10
Peeling Cling Tester	10

2. Paper and Board Testing	10
Bursting Tester	10
Rub Tester	10
COBB Tester	11
Tear Tester	11
Plybond Tester.....	11
Puncture Tester	11
Stiffness Tester.....	12
Folding Tester	12
Core Compression Tester.....	12
Crush Tester	12
Smoothness Tester.....	13
Thickness Gauges	13
Beating and Freeness Tester	13
Concora Medium Flutter.....	14
Paper Dirt Tester.....	14
Softness Tester	14
Air Permeance Tester	15
Taber Stiffness Tester	15
Short Span Compression Tester.....	15
Vertical Tensile Tester.....	16
Horizontal Tensile.....	16
Sample Cutters	16



3. Container Testing	17
Box Compression Tester	17
Package Compression Tester	17
Torque Tester	17
Manual	17
Automatic	17
Bottle Verticality Tester	17
Bottle Thickness Tester	18
Carbonation Tester	18
Cup Lid Peeling Tester	18
Vibration Test Machine	18

4. Medical and Pharmaceutical Testing	19
Ampoule Breaking Tester	19
Tablet Hardness Tester	19
Softgel Hardness Tester	19
Needle Puncture Tester	19
Syringe Tester	20
Vacutainer Drawing Volume Tester	20
Medical Packaging Tester	20
Glass Grain Sampler	21
5. Color Testing.....	21
Haze Meter	21
Colorimeter Meter	21
Spectrophotometer.....	22
Gloss Meter.....	22
6. Adhesiveness Testing.....	22
Ball Tack Tester	22
Holding Power Tester.....	22
Loop Tack Tester.....	23
High Speed Unwinding Tester.....	23
Slow Speed Unwinding Tester	23
90° Peeling Tester	23
180° Peeling Tester	23
7. Plastics Testing	23
Melt Flow Rate Tester	23
Izod Impact Tester	24
Charpy Impact Tester	24
8. Textile Testing	24
Yarn Shrink Rate and Force Tester	24
Cleaning Efficacy Tester	25
Mop Cloth Coefficient of Friction Tester	25
Mop Friction Force Tester	25
9. Texture Analysis	26
Gel Strength Tester	26
Texture Analyzer	26

10. Electronic Products Testing	26
Stylus Pen Testing	26
IEC 60068 Automatic Pendulum Hammer	27
More to be listed...	

1. Plastic Film and Package Testing/Leak Tester

Vacuum Leak Tester is a very common way to check seal integrity of packaging. Popular standard for this application is ASTM D3078. It's also referred to as water method, or bubble emission method. Methylene blue dye solution method is also its application.

Standards: ASTM D3078, ASTM D4991(after modified)		
LT-01	LT-02	LT-03
		
Manual type leak tester, with pressure gauge display, manual time and pressure regulating.	1st generation automatic and digital leak tester, with precious timer and pressure control and display.	2nd generation PLC controlled, HMI touch screen automatic model, with embedded user-friendly program.
Pressure Range: 0~90 KPa		
Test Space: 270mm*210mm φ*H (usable space) Other size and shape available		
Gas input: 0.7 MPa Compressed air by φ6mm pipe		
No Electricity Needed	Power: 220V 50/60HZ	Power: 110~220V 50/60HZ

Gross Leak Tester is a destructive test method for detecting gross leaks in packaging by internal pressurization. This is also called the bubble test and is primarily used for pouch, sterile packaging, etc.

Standards: ASTM F2096
GLT-01

Pressure range: 0~30KPa (or as required)
Test Space: as required
Gas input: 0.7 MPa Compressed air by φ6mm pipe
Power: 110~220V 50/60HZ

Micro Leak Tester is based on vacuum decay method, and is a non-destructive way for leak testing of rigid and semi-rigid non-lidded trays; trays or cups sealed with porous barrier lidding materials; rigid, nonporous packages; and flexible, nonporous packages.

Standards: ASTM F2338
MLT-01

Pressure range: 0--101 KPa
Sensitivity: 1~3μm leakage
Vacuum source: external vacuum pump
Power: 110~220V 50/60HZ

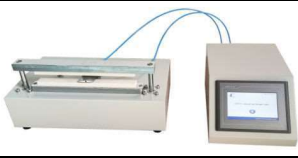
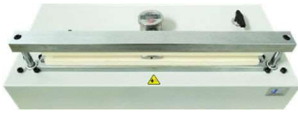



1. Plastic Film and Package Testing/Burst Tester

Burst Tester, also called the leak and seal strength tester, helps to determine the ability of an open or closed package to withstand internal pressurization.

Standards: ASTM F1140, ASTM F2054		
LSST-01 Closed Pack	LSST-01 Open Pack	LSST-01S Open Pack
		
Three test methods of burst, creep and creep to failure. Different units available.		Digital gauge operation and display, Burst test value auto recording.
Pressure Range: 0~600KPa (or as required)		
Gas input: 0.7 MPa Compressed air by $\phi 6$ mm pipe		
Power: 110~220V 50/60HZ		No Electricity Needed

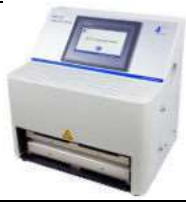

1. Plastic Film and Package Testing/Heat Seal Tester

Heat Seal Tester is a lab sealer, which is used for evaluation of sealing parameters of time, pressure and temperature, before the material is used for packing line in large scale.

Standards: ASTM F2029			
HST-01	HST-02	GHS-01 Gradient	GHS-02 Gradient
			
PLC controlled, HMI touch screen, PID control, pressure transducer inside	LED digital type, PID control, pressure gauge display	LED digital type, PID control, pressure gauge display, 5 independent upper jaws	PLC, HMI screen, PID control, pressure transducer inside, 5 independent upper jaws
Temp Range: Ambient~300°C		Temp Range: Ambient~250°C	
Seal Jaw: 330 mm × 10 mm(upper)		Seal Jaw: 40mm×10mm×5 PCS (upper)	
Sealing Time: 0.1s ~ 9999S	Sealing Time: 0.1s ~ 999H	Sealing Time: 0.1s ~ 999H	Sealing Time: 0.1s ~ 9999S
Sealing Pressure: 0.15 MPa ~ 0.7 MPa			
Power: 220V 50/60HZ			





1. Plastic Film and Package Testing/Hot Tack Tester

Hot Tack Tester measures the strength of heat seals formed between thermoplastic surfaces of flexible webs, immediately after the seal has been made and before it cools to room temperature.

Standards: ASTM F1921	
HTT-01 Horizontal Type	HTT-02 Vertical Type
	
Temp Range: Ambient~250°C	
Test Range: 200N (or as required)	
Dwell Time 0.1s ~ 9999S	
Sealing Pressure: 0.15 MPa ~ 0.7 MPa	
Seal Jaws: 50 mm × 10 mm	
ASTM F1921 Method A	ASTM F1921 Method A and B
Power 220V 50/60HZ	



1. Plastic Film and Package Testing/Tensile Tester

Tensile Tester is a basic tool for checking mechanical properties of materials. It has various styles and load ranges, depending on the sample nature. Below TST-01 is specially designed for flexible packaging industries and have multiple test programs for different test types.

TST-01	TST-01S	TCT-01	TCT-01C	Other UTM
				
PLC controlled, HMI touch screen, multiple test program	PLC controlled, HMI touch screen, multiple test program	Economic key panel operated,	PC Controlled type UTM, range from 50N~5000N	PC Controlled type UTM, range from 10KN and above
Major functions: tensile, elongation, strength, peel, tear, protrusion, penetration, etc		Major functions: tensile, elongation, strength, compression, bending, etc		
Test Range: 500N	Test Range: 500N	Test Range up to 5000N	Test Range up to 5000N	Test Range \geq 10000N
Accuracy: 0.5% F.S.	Accuracy: 0.5% F.S.	Accuracy: 1% F.S.	Accuracy: 1% F.S.	Accuracy: 0.5%, 1% F.S.
Speed: 1-500 mm/min				
Clamps Width 27mm (standard)		Clamps Width 50mm (standard)		
Stroke 800mm	Stroke 200mm	Stroke 1000mm	Stroke 600mm	Stroke 600mm
Power 110~220V 50/60HZ		Power: 220V 50/60HZ		

1. Plastic Film and Package Testing/Coefficient of Friction Tester

Coefficient of Friction Tester is a basic tool for checking surface property of various materials, and it is used to measure static and kinetic coefficients of friction of plastic films, sheets, rubber, paper and paper board, textile, fabrics, cables, convey belts, wood, coatings, brake pads, windshield wipers, shoe materials and tires.

Standards: ASTM D1894, ISO 8295, TAPPI T816	Standards: ASTM D202, TAPPI T815, TAPPI T548
COF-01 Horizontal Type	COF-03 Inclined Type
	
Function: both static and kinetic COF	Function: static COF only
Test range: 5N	Test range: 0° ~ 60°
Sled:200g	Sled: 200g, 235g or 1300g
Test Speed:100, 150mm/min	Test Speed:0.1°/s ~ 10.0°/s
Power 110~220V 50/60HZ	

1. Plastic Film and Package Testing/Impact Tester

Impact Tester is used for evaluating impact toughness of plastics, especially films and sheets.

FDT-01 Dart Impact Tester	FBT-01 Ball Impact Tester	PIT-01 Pendulum Impact Tester
		
Impact Height: 60mm/1500mm	Impact Height:300mm-600mm	N/A
Accuracy: 0.1g (0.1J)	Accuracy: 0.1g (0.1J)	Resolution: 0.001J
Method A: 50~2000g; Method B: 300~2000g	Ball Diameter mm: 23, 25, 28.6, 38.1, 50.8	Impact Energy: 1 J, 2 J, 3 J
Specimen Size: >150*150mm	Specimen Size: >150*150mm	Specimen Size: 100*100mm or Φ 100 mm
ASTM D1709, ISO 7765-1-1988, JIS K7124-1	GB/T15267	ASTM D3420, NF T54-116
Power: 110~220V 50/60HZ		

1. Plastic Film and Package Testing/Thickness Tester

Thickness Tester is a basic tool for checking material thickness. It is important index because any physical and mechanical properties of paper, paperboard and flexible packaging materials are dependent upon the thickness of the material.

Standards: ISO4593, ISO 534, ISO 3034, ASTM D374, ASTM D1777, TAPPI T41	
FTT-01	
	
Test range: 0~2mm	
Resolution: 0.1μm	
Measure Head: Hemispherical or Flat type	
Power: 110~220V 50/60HZ	



1. Plastic Film and Package Testing/Tear Tester

Tear Tester is a standard test for determining the tear resistance, which is named after its inventor, Armin Elmendorf. The Elmendorf test determines the average force required in grams or mN to tear a sample after the tear has been started.

ASTM D1922, ASTM D1424, ASTM D689, ISO 6383, ISO 1974	
SLD-01 Tear Tester	SLD-03Tear Tester
	
Automatic	Manual
Pendulum Capacity(gf) : 200,400,800,1600,3200,6400	Measuring Range: (10~1000) mN
Tearing Arm: 104±1mm	
Tearing Initial Angle: 27.5 ±0.5°	
Gas Source: 0.6MPa	N/A
Power 110~220V 50/60HZ	N/A



1. Plastic Film and Package Testing/Flex Durability Tester

Flex Durability Tester is used to measure the resistance against repetitive strain for films, composites and coating films, etc. It is also called Gelboflex.

Standards: ASTM F392	
GFT-01	GFT-02
	
Four Test Station	Three Test Station
Flex Frequency: 45 /minute	
Flex Angle: 440° (90 mm) or 400° (80 mm)	
Horizontal Stroke: 155 mm or 80 mm	
Sample Size: 280 mm x 200 mm	
Twisting Capacity: 2.5 N.m	Twisting Capacity: 3.5 N.m
Power 110~220V 50/60HZ	

1. Plastic Film and Package Testing/Shrink Tester

Shrink Tester is used for the shrinking forces (FSR-01) and shrinkage ratio measurement of heat shrinkable films.

ASTM D2732	ISO 14616, DIN 53369
FST-01	FSR-01
	
Shrink Rate	Shrink Force and Rate
N/A	Force Range: 5 N
Temp. Range: Ambient ~ 200°C	Temp. Range: Ambient ~ 210°C
Temp. Accuracy: 0.3 °C	Temp. Accuracy: 0.5 °C
Power 220V 50/60HZ	

1. Plastic Film and Package Testing/Peel Cling Tester

Peel Cling Tester measures cling between two layers of stretching film and help to determine the property of stretch wrap material ability to adhere to it.

Standards: ASTM D5458
SPC-01

Test range: 5N
Force Accuracy: 0.5% F.S.
Test Speed: 125mm/min
Power: 110~220V 50/60HZ



2. Paper and Board Testing/Bursting Tester

Bursting Tester is used for the bursting strength test of paper and corrugated boards.

ISO 2759	ISO 2758
BNP-01 for Board	ZNP-01 for Paper
	
Test Range: 150 ~5600kpa	Test Range: 70 ~1600kpa
Plate Diameter upper:31.5±0.1mm, lower: 31.5±0.1mm	Plate Diameter upper:30.5±0.1mm, lower: 33.5±0.1mm
Clamping Force: 100kpa~1200kpa(adjustable)	
Resolution: 0.01 KPa	
Power 220V 50/60HZ	

2. Paper and Board Testing/Rub Tester

Rub Tester is to evaluate the scuffing or rubbing resistance of an ink film or fiber surface on container board and corrugated board.

Standards: TAPPI T830, ASTM D5264	
RT-01	RT-02
	
Arc Movement	Straight reciprocating
No. of Test Stations: 2	No. of Test Stations: 1
Rub Pressure: 8.9 N(2lb); 17.8N(4lb)	Rub Pressure: 20N (4.5lb)
Rub Speed: 20~120 cpm adjustable	Rub Speed: 21, 43, 85, 106cpm
Power 110~220V 50/60HZ	Power 220V 50/60HZ

2. Paper and Board Testing/COBB Tester

COBB Absorption Tester is for the measurement of surface water absorption of paper and paper board.

Standards: ISO 535
COBB-01 COBB Tester

Sample Size: 100cm ²
Metal Roller Diameter: 112.8±0.2mm
Metal Roller Mass: 10±0.5kg

2. Paper and Board Testing/Tear Tester

Tear Tester is used for determining the tear resistance and tear index of paper.

Standards: ASTM D1922, ASTM D1424, ASTM D689, ISO 6383, ISO 1974	
SLD-02 Tear Tester	SLD-03Tear Tester
	
Automatic	Manual
Range(gf): 10~8000 mN, 8000~16000 mN	Measuring Range: (10~1000) mN
Tearing Arm: 104±1mm	
Tearing Initial Angle: 27.5 ±0.5°	
Gas Source: 0.6MPa	N/A

2. Paper and Board Testing/Plybond Tester

Plybond Tester is used for the internal bond strength test of paper and board. It is also called internal bond tester (Scott Type).

Standards: TAPPI T569
BGT-01 Internal Bond Tester

Range(J/M ²): A: 0-500 B: 500~1000 C: 1000~1500
Sample clamp force: 0~40kg/cm ² (adjustable)
Impact angle: 90°
Power 220V 50/60HZ

2. Paper and Board Testing/Puncture Tester

Puncture Tester measures the energy required to puncture board with a pyramidal head affixed to a pendulum arm.

ISO 3036, ASTM D781, DIN 53142, TAPPI T803
PST-01 Puncture Tester

Test Range: (1~48)
Four gears: A < 6J; B < 12J; C < 24J; D < 48J
Resolution: 0.001J
Pressure head: (100±2) KPa
Power 220V 50/60HZ

2. Paper and Board Testing/Stiffness Tester

Stiffness Tester is used to evaluate the stiffness and resiliency of cardboard by international Taber method.

Standards: ISO 5628, ISO 2493
WTD-01 Stiffness Tester

Test Range: 15-10000mN
Sample size: 38*70mm
Bending length: (50/25/20/15/10/5±0.1)mm
Bending angle: 1-90° adjustable
Power 220V 50/60HZ

2. Paper and Board Testing/Folding Tester

Folding Tester is used to test folding endurance of paper, paperboard and other sheet material.

Standards: ISO 5626, TAPPI T511
NZD-01 MIT Folding Tester

Test Range: 0 ~ 99999 times
Folding Angle: 0°~142° adjustable
Folding Speed: 10~2000 times/min adjustable
Tension: 4.9N, 9.8N, 14.7N
Power 220V 50/60HZ

2. Paper and Board Testing/Core Compression Tester

Core Compression Tester is used to test compressive strength and stacking strength of paper tubes. It can be used for small carton, color boxes, paper pallets, paper tubes, paper drums and other paper products.

Standards: ISO12048, TAPPI T804
CST-PC Core Compression Tester

Test Range: (25~10000) N
Testing Space: 300*170*300 mm
Test Speed: 55mm/min adjustable
Resolution: 0.1N
Power 220V 50/60HZ

2. Paper and Board Testing/Crush Tester

Crush Tester is used for the ring crush (RCT) for paper with thickness between 0.15 and 1mm, edge crush (ECT), plybond adhesion (PAT) and flat crush (FCT) test for board. I

Standards: ISO12048, TAPPI T804
YSD-01 Crush Tester

Test Range: (5~3000) N
Plates Diameters: 125 mm
Test Speed: 12.5±1mm/min
Resolution: 0.1N
Power 220V 50/60HZ



2. Paper and Board Testing/Smoothness Tester

Smoothness Tester is used for the determination of smoothness of paper and board according to Bekk Method.

Standards: ISO 527, DIN 53107, TAPPI T479
ST-01 Smoothness Tester

Test Range: 5s,(15 ~ 300)s, ≥ 300s
Test area:(10±0.05) cm ²
Test Pressure: (100±2) KPa
Power 220V 50/60HZ

2. Paper and Board Testing/Thickness Gauge

Thickness Gauges are desktop type thickness measurement devices for paper, board and tissue.

Standards: ISO 438	ISO 534	ISO 12625-3
ZBH-01 Paper Thickness Tester	PBT-01 Board Thickness Tester	THD-01 Tissue Thickness Tester
		
Test Range (0~4) mm	Test Range (0~20) mm	Test Range (0~4) mm
Contact Area (200±5)mm ²	Contact Area (1000±20)mm ²	Contacting area: (1000±20) mm ²
Contact Pressure 100±10 KPa	Contact Pressure 20±2 KPa	Contacting pressure: 2±0.1 KPa
Resolution: 0.001mm		

2. Paper and Board Testing/Beating and Freeness Tester

Beating and Freeness Tester is used for the determination of the drainability of a pulp suspension in water in terms of the Schopper-Riegler (SR) number.

Standards: ISO 5627-1, GB/T 3332, QB/T 1054		
DJD-01	DJD-02	DJD-03
		
Test Range 1~100 SR		
Operation: Manual	Auto Release	
Orifice Draining Time: 149±1s		
Residual Volume: (7.5~8.0)ml		

2. Paper and Board Testing/Concora Medium Fluter

Beating and Freeness Tester is used for the determination of the drainability of a pulp suspension in water in terms of the Schopper-Riegler (SR) number.

Standards: CMT: ISO 7263, TAPPI T843, EN ISO 7263-1 CCT: ISO 16945, TAPPI T843
CWY-01 Concora Medium Fluter

Radius Of Teeth At Peak $R 1.5 \pm 0.1\text{mm}$
Radius Of Teeth At Base $R 2.0 \pm 0.1\text{mm}$
Depth Of Teeth $4.75\pm/-0.05\text{mm}$
Distance Between Teeth $8.50 \pm 0.05 \text{ mm}$
Flute Type A (standard)
Speed $4.5 \pm 0.1 \text{ r/min}$
Power 220V 50/60HZ

2. Paper and Board Testing/Paper Dirt Tester

The degree of dirt is the amount of dirt with a certain area per square meter of paper and cardboard, or the equivalent area (mm^2) of dust on paper and cardboard per square meter

Standards: GB/T 1541
PDT-01 Paper Dirt Tester

Lighting 20W fluorescent lamp
Lighting angle 60°
Working area 0.0625m^2 , 360° rotatable
Standard dirt picture $0.05\text{--}5.0 \text{ (mm}^2\text{)}$

2. Paper and Board Testing/Softness Tester

RRD-01 Softness tester is used for the determination of the stiffness of tissue, non-woven, tobacco sheet, fabrics etc. by measuring the force required to push a specimen into a slot.

Standards: ASTM D2063, ASTM D3198, ASTM D3474
RRD-01 Softness Tester

Test Range (10~1000) mN
Test Blade Size R. mm, $120\text{mm} \times 2\text{mm} \text{ L} \times \text{D}$
Blade Stroke $8 \pm 0.5\text{mm}$
Test Speed 1.2mm/s
Force Resolution 1mN
Accuracy $\pm 1\%$
Slot Width 5mm, 6.35mm, 10mm, 20mm
Power AC 220V 50Hz

2. Paper and Board Testing/Air Permeance Tester

TQD-01 Air Permeance Tester is used to determine the air permeance of paper and board in the medium air permeance range using the Schopper method.

Standards: ISO 5636-2, ISO 5636-3, ISO 5636-5
TQD-01 Air Permeance Tester

Test Range (1 ~ 1000) ml/min or 0~17um/(Pa.s)
Test Area 10±0.2cm ²
Test Area Pressure Difference 1±0.01kpa
Accuracy <100ml, error 1ml; >100ml, error 5ml
Clamp Ring Inner Diameter 35.68±0.05mm
Clamp Rings Center Coaxiality <0.05mm

2. Paper and Board Testing/Taber Stiffness Tester

WTD-02 Taber Stiffness Tester is used to measure the bending resistance of paper and paperboard by the Taber-type tester.

Standards: ASTM D5342, ASTM D5650, ASTM D3301, BS ISO 2493.2, ISO 2493.2, JIS P8125.2, TAPPI T489, TAPPI T566
WTD-02 Taber Stiffness Tester

Test range 1~500 mN.m (in 7 ranges)
Indication error ±2%
Bending length 50mm±0.1mm
Testing speed (200°±20°) /min
bending angle 15°±0.3° and 7.5°±0.3°
Sample size 38*70 mm

2. Paper and Board Testing/Short Span Compression Tester

SCT-01 Short Span Compression Tester is used for determining the compressive strength in the machine and cross-directions of paper and board.

Standards: ISO 9895, GB/T 2679.10
SCT-01 Short Span Compression Tester

Test Range 1~500N(0.06~33.3 KN/m)
Compression Distance 0.3~0.7mm
Clamping Length 30±0.5mm
Test Speed 3±0.1mm/min
Resolution 0.01N
Sample Size 15*75mm W*L

2. Paper and Board Testing/Vertical Tensile Tester

TST-V Vertical Tensile Tester is a constant-rate-of-elongation equipment which is used for the determination of the tensile strength, stretch at maximum force and tensile energy absorption, tensile stiffness of paper, paperboard, tissue paper and tissue products. It also calculating the tensile index and the tensile energy absorption index.

Standards: ISO 1924-1, ISO 1924-2, ISO 1924-3, ISO 12625-4, ISO 12625-5, TAPPI T494
TST-V Vertical Tensile Tester

Measurement range 500N or as required
Elongation Range 800mm
Stretching speed 1~500 mm/min
Test speed accuracy ±0.1mm/min
Force accuracy 0.5% F.S.
Force accuracy ±0.1% (20~100%FS)
Deformation resolution ≤0.01mm

2. Paper and Board Testing/Horizontal Tensile Tester

TST-H Horizontal Tensile Tester is a constant-rate-of elongation equipment which is used for the determination of the tensile strength, stretch at maximum force and tensile energy absorption, tensile stiffness of paper, paperboard, tissue paper and tissue products.

Standards: ISO 1924-1, ISO 1924-2, ISO 1924-3, ISO 12625-4, ISO 12625-5, TAPPI T494
TST-H Horizontal Tensile Tester

Measurement range 30N, 500N or as required
Elongation measurement range 45-260mm
Stretching speed (1~500) mm/min
Return speed 100mm/min
Clamp spacing 1~250mm
Test speed accuracy (1~10) mm/min: ±0.1mm/min



2. Paper and Board Testing/Sample Cutters

Sample Cutter is used to make paper and board samples in an efficient and accurate way.

Strip Sample	ECT Edge Crush	RCT Ring Crush	Strip Sample	HAND GSM	MANUAL GSM	PNEUMATIC GSM
						
10, 15, 25.4mm	25*100 mm	152*12.7 mm	15*300mm	100 cm ²	100 cm ²	100 cm ²

3. Container Testing/Box Compression Tester

Box Compression Tester is for the compression strength and stacking ability of medium and small size packaging like corrugated carton, barrel, bottle, etc.

Standards: ISO12048, TAPPI T804	
CST-S (small size)	CST-M/L(M/L size)
	
Test Range 10KN	
Compressing Speed: 12mm/min	
Stacking Speed: 5mm/min	
Test Space: 400*600*600mm (LWH)	Test Space: 600*800*800; 800*1000*1000; 1000*1200*1200; 1200*1200*1200
Power 220V 50/60HZ	

3. Container Testing/Package Compression Tester

Package Compression Tester is for the compression strength and stacking ability of medium and small size packaging like corrugated carton, barrel, bottle, etc.

Standards: GB/T 10004, YBB 00112005
PCT-01 Package Compression Tester

Test Range: 2000N
Platen Size: 250mm*300mm
Time range: 0~10000S
Power 110~220V 50/60HZ

3. Container Testing/Torque Tester

Torque Tester measures the open force and lock force of the caps of medicine bottles, PET bottles, spout bags and flexible tube packages.

Standards: ASTM D2063, ASTM D3198, ASTM D3474		
TT-01 Torque Tester	MCT-01 Torque Tester	MCT-01L Torque Tester
		
Manual	Lower Automated	Upper Automated
Test Range: 10N.m		
Resolution: 0.001 Nm		
Clamp Range: Φ~Φ170mm	Clamp Range: Φ~φ80mm for cap, Φ~φ170mm for bottle	
Power 110~220V 50/60HZ		



3. Container Testing/Bottle Verticality Tester

Bottle Verticality Tester is also called bottle perpendicularity tester, deviation tester, coaxial tester, coaxiality, or circle runout tester (for vials etc.)

PER-01 Perpendicularity Tester

Sample Diameter: 5mm~145mm
Test Range: 0~12.7mm
Division value: 0.01 or 0.001mm
Measurable Height: 15mm~300mm



3. Container Testing/Bottle Thickness Tester

Bottle Thickness Tester measures the open force and lock force of the caps of medicine bottles, PET bottles, spout bags and flexible tube packages.

WTT-01 Wall Thickness	WTT-02 Wall Thickness
	
Sample Diameter: 5~50mm	Sample Diameter: 10~120mm
Test Range: 12.7mm	
Division value: 0.01 or 0.001mm	
Measurable Height: 100mm	Measurable Height: 300mm

3. Container Testing/Carbonation Tester

Carbonation Tester is suitable for beverage carbon dioxide volume testing and gives a way to find out relationship between pressure and temperature.

Standards: ASTM F1115, GB T10792	
CLRT-01 Carbonation Tester	CLRT-02 Carbonation Tester
	
Automated	Manual
Resolution: 0.01KPa	Resolution: 0.0001 MPa
Shaking Speed: Adjustable	Manual
Test Range: 0~1 MPa	
Power 110~220V 50/60HZ	N/A

3. Container Testing/Cup Lid Peeling Tester

CCPT-01 Cup and Container Peeling Tester is used to measure the mechanical seal strength while separating the entire lid(cover/membrane) from a rigid or semi-rigid round container.

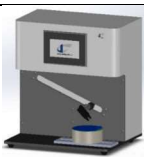
Standards: ASTM F2824
CCPT-01 Cup and Container Peeling Tester

Test Range 500N (or as required)
Stroke 260mm
Speed 1 ~ 500mm/min
Gas Pressure 0.6 MPa
Power AC 110~220V 50/60Hz

3. Container Testing/Vibration Test Machine

VTM-01 Vibration Test Machine is used to carry out vibration tests on complete, filled transport packages or unit loads using sinusoidal excitation at fixed frequency.

Standards: ASTM D 999, ISTA series, ISO 2247
VTM-01 Vibration Test Machine

Max Load 100kg (can be customized)
Speed 100~300rpm
Accuracy 1rpm
Vibration Amplitude 25.4mm
Speed Simulation 25~40km/h
Work Bench 1200mm*1000mm(L*W)
Max Load 100kg (can be customized)
Power AC 220V 50Hz

4. Medical and Pharmaceutical Testing/Ampoule Breaking Tester

Ampoule Breaking Tester is used for the quantitative test of ampoule breaking strength.

Standards: ISO 9187, GB 2637
BST-01 Ampoule Breaking Tester

Test Range: 0~200 N
Test Speed: 1~500mm/min
Resolution: 0.1 N
Accuracy: 0.5% F.S.
Power 110~220V 50/60HZ

4. Medical and Pharmaceutical Testing/Tablet Compression Tester

Tablet Compression Tester is used for the hardness or compression force and displacement measurement of materials.

MPT-02 Tablet Tester

Test Range: 200N
Speed: 1~500mm/min
Resolution: 0.5% F.S.
Power 110~220V 50/60HZ

4. Medical and Pharmaceutical Testing/Softgel Hardness Tester

The CHT-01 Capsule and Softgel Hardness Tester performs a penetration or compression test to quantify the softgel's elasticity and rupture force.

CHT-01 Softgel Hardness Tester

Test Range: 200N
Stroke: 200mm (without clamp)
Speed: 1~300mm/min (or as required)
Resolution: 0.5% F.S.
Power 110~220V 50/60HZ

4. Medical and Pharmaceutical Testing/Needle Puncture Tester

NPT-01 Needle Puncture Tester can be equipped with multi types of needles and different types of samples holding jigs to meet demands of needle puncture testing across various materials.

Standards: ISO 7864, GB 15811, GB/T 10004, ASTM F2878, ASTM F1342, EN 388
NPT-01 Needle Puncture Tester

Test Range: 200N
Stroke: 200mm (without clamp)
Speed: 1~500mm/min (or as required)
Resolution: 0.5% F.S.
Power 110~220V 50/60HZ

4. Medical and Pharmaceutical Testing/Syringe Tester

MST-01 Medical Syringe Tester is used for the mechanical verifying of the design of empty sterile single use hypodermic syringes, with or without needle, made of plastic or other material and intended for the aspiration and injection of fluids after filling by the end-user.

Standards: ISO 7886-1
MST-01 Medical Syringe Tester

Test Range: 50N (or as required)
Stroke: 200mm (without clamp)
Speed: 1~500mm/min (or as required)
Resolution: 0.5% F.S.
Power 110~220V 50/60HZ









4. Medical and Pharmaceutical Testing/Vacutainer Drawing Volume Tester

Vacutainer Drawing Volume Tester is used to creates a high-altitude environment to check the performance of blood collection tubes.

Standards: BS EN 14820, ISO 6710
RDVT-01 Drawing Volume Tester

Test Range: 0--40KPa
Power 110~220V 50/60HZ

4. Medical and Pharmaceutical Testing/Medical Packaging Tester

Medical Packaging Tester is designed for the measurement of force properties of a variety of medical packaging materials, such as tensile, compression, strength, tear, opening, penetration, breaking and pull test of polymers, bags, ampoule, rubber stopper, syringe, needle etc.

MPT-01 Medical Packaging Tester			
			
Test Range: 0~500 N			
Test Speed: 1~500mm/min			
Resolution: 0.1 N			
Accuracy: 0.5% F.S.			
Power 110~220V 50/60HZ			
			
			





4. Medical and Pharmaceutical Testing/Glass Grain Sampler

Glass Grain Sampler is also called glass grain hydrolytic resistance tester and it is used in the preparation of glass grain and particle water resistance test samples.



Standards: ISO 719, ISO 720
GHR-01A Glass Grain Hydrolytic Resistance Tester

Mortar/Pestle Dimension: $\Phi 50/\Phi 48$ mm
Sieve A Aperture: 425 μ m
Sieve B Aperture: 300 μ m
Sieve O Aperture: 600~1000 μ m
Power 110~220V 50/60HZ



5. Color Testing/Haze Meter

ASTM D1003/D1044	ASTM D1003/1044, ISO 13468/14782		
Haze-09	Haze-100	Haze-111	Color Haze-700
			
CIE-A, CIE-C, CIE-D65			CIE-A, CIE-C, CIE-D65&24 Chromaticity index
Aperture: 21mm		Aperture: 21mm, 7mm	
ASTM (HAZE), Transmittance (T)	ASTM and ISO (HAZE), Transmittance (T)		CIE-A, CIE-C, CIE-D65&24 Chromaticity index Illumination Area and Aperture: 16.5mm/21mm ASTM and ISO (HAZE), Transmittance (T), Color
5" Full Color Screen		Android, 7" Full Color Screen	
Haze Resolution: 0.01 unit; Transmittance Resolution: 0.01 unit			
400~700nm full spectrum LED light source			



5. Color Testing/Colorimeter

Standards: CIE No.15, GB/T 3978, GB 2893, GB/T 18833, ISO7724-1, ASTM E1164, DIN5033 Teil7		
Color-200	Color-210	Color-220
		
D/8, SCI		
$\Delta E^*ab \leq 0.03$		
Aperture: $\Phi 6$ mm	Aperture: $\Phi 11$ mm, $\Phi 6$ mm	Aperture: $\Phi 11$ mm, $\Phi 6$ mm, $\Phi 3$ mm
A, B, C, D50, D55, D65, D75, F1, F2, F3, F4, F5, F6, F7, F8, F9, F10, F11, F12, CWF, U30, U35, DLF, NBF, TL83, TL84, ID50, ID65, LED-B1, LED-B2, LED-B3, LED-B4, LED-B5, LED-BH1, LED-RGB1, LED-V1, LED-V2		
Observation: Eye	Observation: Camera	
Light Source: LED	Light Source: LED+UV	

5. Color Testing/Spectrophotometer

SP-520	SP-700 Series(multiple available)
	
Reflectance, CIE-Lab, CIE-LCh, HunterLab, CIE Luv, XYZ, Yxy, RGB, Color difference(ΔE^*ab , ΔE^*cmc , ΔE^*94 , ΔE^*00), WI(ASTM E313-00, ASTM E313-73, CIE/ISO, AATCC, Hunter, Taube Berger Stensby), YI(ASTM D1925, ASTM E313-00, ASTM E313-73), Blackness(My,dM), Color Fastness, Tint, (ASTM E313-00), Color Density CMYK(A,T,E,M), Milm, Munsell, Opacity, Color strength	Spectral reflectance, CIE-Lab, CIE-LCh, HunterLab, CIE-Luv, XYZ, Yxy, RGB, chromatic aberration(ΔE^*ab , ΔE^*cmc , ΔE^*94 , ΔE^*00), whiteness(ASTM E313-00, ASTM E313-73, CIE/ISO, AATCC, Hunter, Taube Berger Stensby), Yellowness(ASTM D1925, ASTM E313-00, ASTM E313-73), Blackness(My,dM), Color fastness, Staining fastness, Tint(ASTM E313-00), Color density CMYK(A,T,E,M), Metamerism index Milm, Munsell, covering power, Force share(Color Strength)
A, B, C, D50, D55, D65, D75, F1, F2, F3, F4, F5, F6, F7, F8, F9, F10, F11, F12, CWF, U30, U35, DLF, NBF, TL83, TL84	A, B, C, D50, D55, D65, D75, F1, F2, F3, F4, F5, F6, F7, F8, F9, F10, F11, F12, CWF, U30, U35, DLF, NBF, TL83, TL84, ID50, ID65, LED-B1, LED-B2, LED-B3, LED-B4, LED-B5, LED-BH1, LED-RGB1, LED-V1, LED-V2
Repeatability: Max. $\Delta E^*ab < 0.04$; Average $\Delta E^*ab < 0.03$	Repeatability: $\Delta E^*ab \leq 0.025$
Illumination Area/Aperture: MAV: $\Phi 8\text{mm}/\Phi 11\text{mm}$; MAV: $\Phi 4\text{mm}/\Phi 6\text{mm}$; MINI: $1 \times 3\text{mm}$	Measuring aperture: 4 stable and smart: $\Phi 11\text{mm}$, $\Phi 6\text{mm}$, $\nabla 11\text{mm}$, $\nabla 6\text{mm}$
Geometry: D/8, SCI+SCE	

5. Color Testing/Gloss Meter

Standards: DIN 67530, ISO 2813, ASTM D 523, JIS Z8741, BS 3900 Part D5, JIG696	
Gloss-300	Gloss-380
	
60°	20°, 60°, 85°
Light Spot: 60°: 9*15 mm	Light Spot (mm): 20°: 10*10; 60°: 9*15; 85°: 5*38
Test Range: 60°: 0-1000GU	Test Range (GU): 20°: 0~2000; 60°: 0~1000; 85°: 0~160
Repeatability: 0-100GU: 0.2GU; 100-2000GU: 0.2%GU	



6. Adhesiveness Testing/Ball Tack Tester

Ball Tack Tester is used for the measurement of initial adhesion property of adhesive tapes.

Standards: PSTC-6, ASTM D3121, JIS Z0237	Standards: JIS Z0237, GB/T 4852
BTT-01	BTT-02
	
Trough Length 6.5 inch	Inclined Angle 0~60°
Incline Angle 21.3°	Test Area Width 120mm
Rolling Ball 7/16 inch (No. 14)	Rolling Ball 1/32~1 inch

6. Adhesiveness Testing/Holding Power Tester

Holding Power Tester is for the test of lasting adhesive/holding power of pressure sensitive adhesive tapes, labels and other interrelated products.

Standards: ASTM D3654	
LAT-05 Five Station	LAT-10 Tension Station
	
Test Time: 0~100H	
Standard Roller: 2000 g \pm 50 g	
Test Load: 1000 \pm 10g	
Test Plate: 60(L) mm \times 40(B) mm \times 1.5(D) mm	
Power 220V 50/60HZ	

6. Adhesiveness Testing/Loop Tack Tester

Loop Tack Tester is used for adhesive, tape and label in the measurement of their sticking force, adhesiveness and tack, etc.

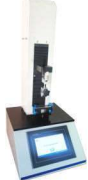
Standards: PSTC 16 FINAT 9, ASTM D6195
LTT-01 Loop Tack Tester

Test Range: 200N
Speed Range: 1~500mm/min
Sample Size: 125*25mm
Power 110~220V 50/60HZ







6. Adhesiveness Testing/High Speed Unwinding Tester

High Speed Unwinding Tester is used for adhesive, tape and label in the measurement of their sticking force, adhesiveness and tack, etc.

Standards: PSTC-13, ASTM D1000
HSU-01 High Speed Unwind Force Tester

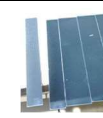
Test Range: 10kg, 20kg, or 50kg
Reel Diameter: 75mm (or others)
Power 110~220V 50/60HZ



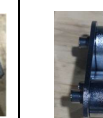

6. Adhesiveness Testing/Slow Speed Unwinding, 90° Peeling, 180° Peeling

Slow Speed Unwinding, 90° Peeling and 180° Peeling tests can be performed on TST-01 tensile tester with jigs like tape roll holder, test plate, 2kg roller, 90° peeling jig, etc.

Slow Speed Unwinding, 90° Peeling, 180° Peeling Test			
			
			

7. Plastics Testing/Melt Flow Rate Tester



Melt Flow Rate Tester is suitable to measure melt flow character of PP, PE, POM, ABS plastics, PC etc.

RZ-A	RZ-B	RZ-W	RZ-C	RZ-H
				
MFR	MFR&MVR			
LED	PLC, touch Screen		PC, Touch Screen, microprocessor	RS485、USB, Touch Screen
N/A	N/A	Yes		N/A
0.1-400g	0.1-800g(MFR) 0.1-800cm³(MVR)		0.1-3000g(MFR) 0.1-3000cm³(MVR)	(0.01 ~ 200)g(MFR) (0.1 ~ 2500)cm³(MVR)
Ambient~450°C				

	±0.2°C	±0.5°C	±0.2°C
1S or 0.01S	0.1S		
0.01mm			
Full Load 0.325~21.6kg			
Manual, Time	Manual, Time, auto		Electric (Auto)
9.550mm ± 0.025mm			
160mm			
Tungsten Carbide, L8.000mm ± 0.025mm, Internal Diameter 2.095mm ± 0.005mm			
0.45 KW		0.5 KW	0.45 KW
AC220V, 50Hz			



7. Plastics Testing/Izod Impact Tester

Izod Impact Tester is used for the determination of impact toughness of non-metallic materials such as rigid plastics, reinforced nylon, FRP, ceramics, cast stone, and electrical insulating materials.

Standards: ISO 180, ASTM D256, GB/T 1843, GB/T 2611	
XB-D Digital Touch Screen	XB-M Manual Mechanical
	
Impact velocity: 3.5m / s	
Impact Energy: 1J, 2.75J, 5.5J, 11J, 22J (one equipped)	
Tilt angle: 160°	
Blade Fillet Radius: R=0.8±0.2mm	
Blade Inclined Angle: 75°	
Power 110~220V 50/60HZ	

7. Plastics Testing/Charpy Impact Tester

Charpy Impact Tester is for toughness test of hard plastics, fiber-reinforced composite material, nylon, fiberglass, ceramics, cast stone, asbestos sheets, insulation materials and other non-metallic materials, including machining and injection molding samples.

Standards: ISO179, GB/T1043	
CH-D Digital Touch Screen	CH-M Manual Mechanical
	
Impact velocity: 3.8m / s	
Impact Energy: 7.5J, 15J, 25J, 50J(one equipped)	
Tilt angle: 160°	
Blade Fillet Radius: R=2±0.5mm	
Blade Inclined Angle: 30±1°	
Power 110~220V 50/60HZ	

8. Textile Testing/Yarn Shrink Rate and Force Tester

Yarn Shrink Rate Tester is used for the shrink rate and force test of yarn and cord at controlled temperature.

Standards: ASTM D4974, ASTM D5591
HAST-01 Hot Air Thermal Shrinkage Tester

Temp. Range: Ambient~250°C
Test Time: 0~9999S
Accuracy: 0.1°C
Force Range: 0~50N (Customization Available)
Force Resolution: 0.01N
Power 220V 50/60HZ

8. Textile Testing/Cleaning Efficacy Tester

Cleaning Efficacy Tester provides an easy way to simulate the use of cleaning material and is a great labor-saving tool for quality and production personal to evaluate the product and produce and develop better quality.

CLEAN-EFF01 Cleaning Efficacy Tester

Speed Range: 1~27000mm/min adjustable
Speed Accuracy: 1mm/min
Test Cycles: 1~20000
Moving Distance: 600mm
Power 110~220V 50/60HZ

8. Textile Testing/Mop Cloth Coefficient of Friction Tester

Mop Cloth Coefficient of Friction Tester is used for mop and cleaning materials, such as mop pad, microfiber, sponge mop constructed with a cellulosic, rubber or plastic foam block. The mop friendliness in friction force will be different when it's used for liquid, dust, dry surface, etc.

COF-S1 Mop Cloth Coefficient of Friction Tester

Force Range: 0~100N
Resolution: 0.5% F.S
Speed Adjustable: 0~1000mm/min
Speed Accuracy: 0.1mm/min
Sled Size and Weight: 100mm*100mm, 225±1g
Moving Distance: 500mm
Power 110~220V 50/60HZ

8. Textile Testing/Mop Cloth Coefficient of Friction Tester

Mop Cloth Coefficient of Friction Tester is used for mop and cleaning materials, such as mop pad, microfiber, sponge mop constructed with a cellulosic, rubber or plastic foam block. The mop friendliness in friction force will be different when it's used for liquid, dust, dry surface, etc.

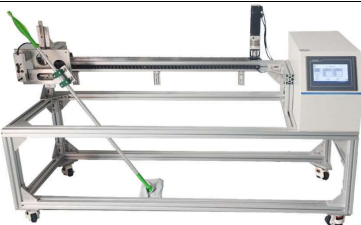
MopFric-01 Mop Friction Force Tester

Force Range: 0~100N
Resolution: 0.5% F.S
Speed Adjustable: 0~1000mm/min
Speed Accuracy: 0.1mm/min
Sled Size and Weight: 100mm*100mm, 225±1g
Moving Distance: 500mm
Power 110~220V 50/60HZ

9. Texture Analysis/ Gel Strength Tester

Gel Strength Tester has a punch probe of a specific diameter and length is used to compress the surface of a gel specimen at a constant deformation rate, until puncture occurs. Normally the speed used is 60mm/min and probe ϕ 5mm.

GST-01 Gel Strength Tester

Test Range: 0~50N
Stroke: 110mm (without probe)
Test Speed: 1~100mm/min
Accuracy: 0.5% F.S.
Power 110~220V 50/60HZ

9. Texture Analysis/Texture Analyzer

A texture analyzer is a specialized instrument used to measure the mechanical properties of materials, particularly their texture, consistency, and structural characteristics.

TEX-01 Texture Analyzer

Test Range: 0~500N (or others)
Stroke:200mm (without probe)
Test Speed: 1~500mm/min
Accuracy: 0.5% F.S.
Power 110~220V 50/60HZ

10. Electronic Products Testing/Stylus Pen Sliding and COF Tester

TSTP-01 Stylus Pen Sliding and COF Tester is specially designed for the durability and friction testing. It has two test modes of linear back and forth sliding test and coefficient of friction test.

TSTP-01 Stylus Pen Sliding and COF Tester

Test Range: 0~5N; 350mm
Speed Adjustable: 1~12000mm/min
Speed Accuracy: 0.1mm/min
Accuracy: 0.5% F.S.
Power 110~220V 50/60HZ

10. Electronic Products Testing IEC 60068 Pendulum Hammer

IEC 60068 Pendulum Hammer Striking Tester determines the ability of a specimen to withstand rigorous and stringent impacts and is used primarily to establish an acceptable level of robustness when assessing the safety of a product.

PHS-01 Pendulum Hammer Striking Tester

Impact Energy: 0.14J, 0.2J, 0.35J, 0.5J, 0.7J, 1J, 2J, 5J
Equivalent Mass: 0.25, 0.25, 0.25, 0.25, 0.25, 0.25, 0.5, 1.7
Height of Fall: 56, 80, 140, 200, 280, 400, 400, 300mm
Plywood: 175*175mm, 8mm thickness by user
Power 110~220V 50/60HZ

Various projects based on customization.



Contact us to get a method/solution/free testing, etc.

Cell Instruments Co., Ltd.

Jinan Cell Electromechanical Co., Ltd.

Headquarters: No. 5577, Gongyabei Rd, Licheng District,
250109, Jinan, Shandong Province, China

www.celtec.cn

www.qualitester.com

www.polytester.com

www.packqc.com

info@celtec.cn

Mobile/WeChat: +86 18560013985